

ViewSonic®

PJ502

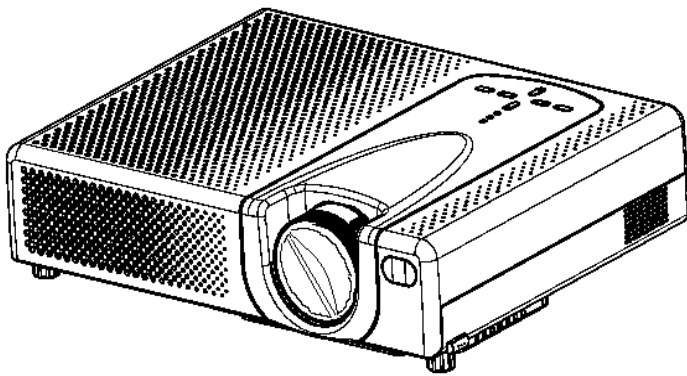

*Image size 30"-300"
High Brightness Light Weight
LCD Projector*

User Guide

Guide de l'utilisateur

Bedienungsanleitung

Guía del usuario

Guida dell'utente

Guia do usuário

Användarhandbok

Käyttöopas

Руководство пользователя

使用手冊

使用手冊

Contents

For Your Records	1
Projector features	2
Package Contents	2
Part names	3
Projector	4
Controls	4
Setting up	5
Arrangement	6
Adjusting the projector's elevator	8
About the filter cover for a unit installed bottom side up	9
Connecting your devices	10
With a computer	11
Connecting power supply	12
Remote control	13
Putting Batteries	13
Operating the remote control	14
Power on/off	15
Turning on the power	15
Turning off the power	15
Operating	16
Adjusting the volume	16
Temporarily muting the sound	16
Selecting an input signal	16
Searching an input signal	17
Selecting an aspect ratio	17
Adjusting the zoom and focus	17
Using the automatic adjustment feature	17
Adjusting the position	18
Correcting the keystone distortions	18
Using the magnify feature	18
Freezing the screen	19
Temporarily blanking the screen	19
Multifunctional setting	20
Using the menu function	20
EASY MENU	21
ASPECT, KEYSTONE, MODE, BRIGHT, CONTRAST, COLOR, TINT, SHRP- NESS, WHISPER, MIRROR, RESET, FILTER TIME, LANGUAGE, Go To Ad- vanced Menu	

Contents

PICTURE menu	22
BRIGHT, CONTRAST, GAMMA, COLOR TEMP, COLOR, TINT, SHARP- NESS, PR-OGRES-SIVE, MY MEMORY	
IMAGE menu	24
ASPECT, OVER SCAN, V POSITION, H POSITION, H PHASE, H SIZE, AUTO ADJUST	
INPUT menu	25
COLOR SPACE, COMPONENT, VIDEO FORMAT, FRAME LOCK, INFOR- MATION	
SETUP menu	26
KEYSTONE, WHISPER, MIRROR, VOLUME	
SCREEN menu	27
LANGUAGE, MENU POSITION, OSD BRIGHT, BLANK, START UP, My- Screen, MyScreen Lock, MESSAGE	
OPTION menu	29
SEARCH, AUTO OFF, AUTO ON, LAMP TIME, FILTER TIME, SERVICE	
Maintenance	31
Lamp	31
Air filter	33
Other care	34
Troubleshooting	35
Related messages	35
Regarding the indicator lamps	36
Phenomena that may easily be mistaken for machine defects	38
Warranty and after-service	40
Specifications	40
Customer Support	42
LIMITED WARRANTY	43
Appendix	44
Power Cord Safety Guidelines	44
Compliance Information for U.S.A.	45
Compliance Information for Canada	45
Compliance Information for European Countries	45
User Information for all Countries	45

Copyright © ViewSonic Corporation, 2004. All rights reserved.

Apple, Mac and ADB registered trademarks of Apple Computer, Inc.

Microsoft, Windows, Windows NT, and the Windows logo are registered trademarks of Microsoft Corporation in the United States and other countries.

ViewSonic, the three birds logo and OnView are registered trademarks of ViewSonic Corporation.

VESA and SVGA are registered trademarks of the Video Electronics Standards Association.

DPMS and DDC are trademarks of VESA.

PS/2, VGA and XGA are registered trademarks of International Business Machines Corporation.

Disclaimer: ViewSonic Corporation shall not be liable for technical or editorial errors or omissions contained herein; nor for incidental or consequential damages resulting from furnishing this material, or the performance or use of this product.

In the interest of continuing product improvement, ViewSonic Corporation reserves the right to change product specifications without notice. Information in this document may change without notice.

No part of this document may be copied, reproduced, or transmitted by any means, for any purpose without prior written permission from ViewSonic Corporation.

Electronic Warranty Registration

To meet your future needs, and to receive any additional product information as it becomes available, please register your projector's warranty on the Internet at: <http://www.viewsonic.com>

For Your Records

Product Name:	ViewSonic PJ502
Model Number:	VS10185
Document Number:	A-CD-PJ502
Serial Number:	_____
Purchase Date:	_____

Projector features

This projector is used to project various computer signals as well as NTSC/PAL/SECAM video signals onto a screen. Little space is required for installation and large images can easily be reached.

Package Contents

Your projector should come with the following items. Contact your dealer immediately if anything is missing.

- (1) Projector
- (2) Remote control (with two AA batteries)
- (3) Power cords
- (4) RGB cable
- (5) Video cable
- (6) Filter cover for bottom-up use
- (7) Soft case
- (8) Quick Start Guide
- (9) ViewSonic Wizard CD
- (10) Rivet & Strap

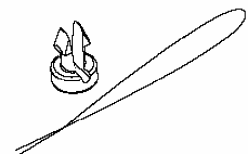
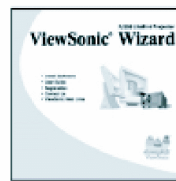
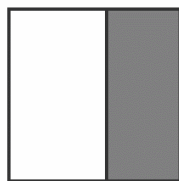
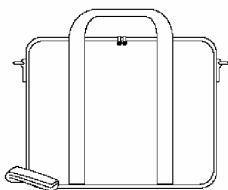
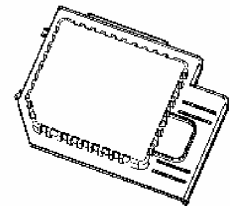
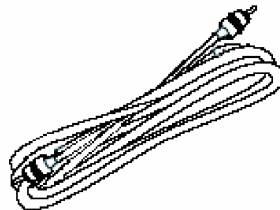
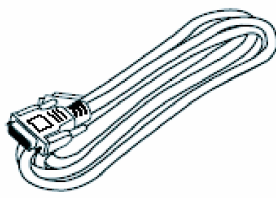
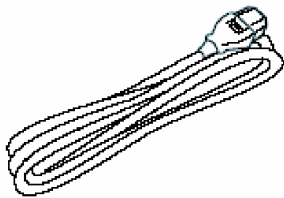
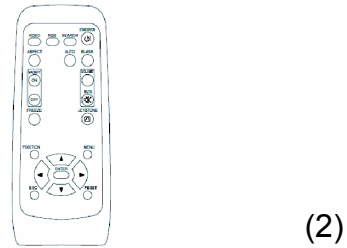
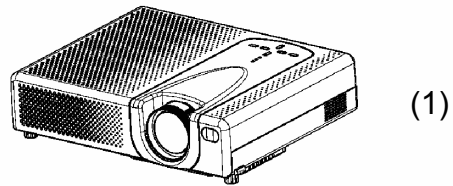

NOTE . Keep the original packing materials for future reshipment. When transporting, be sure to use the original packing material. Use special caution to protect the lens.

Part names

Projector

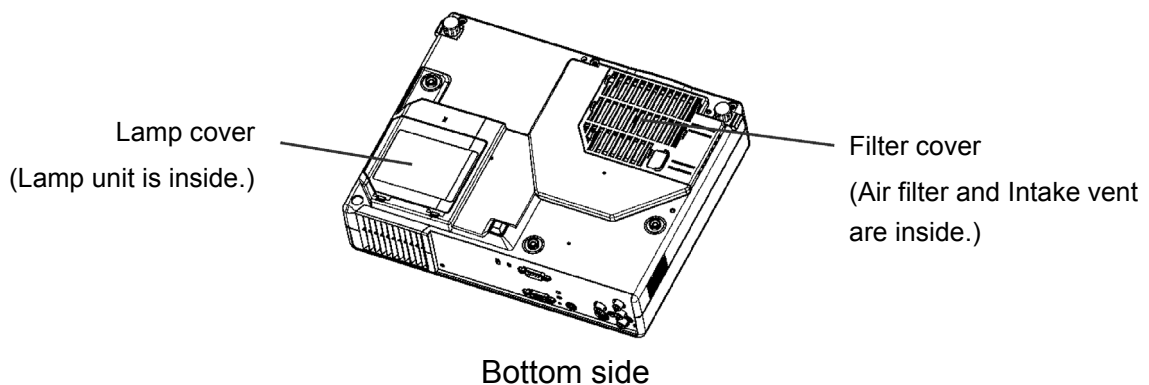
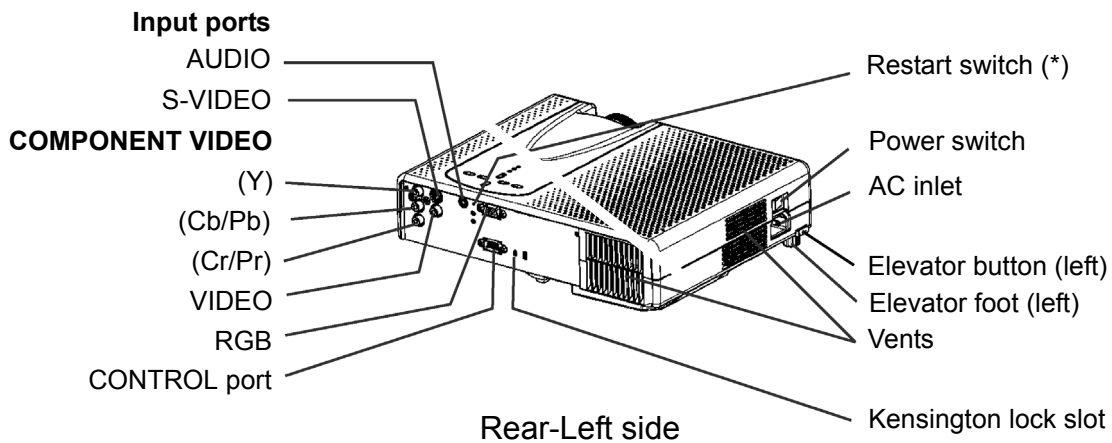
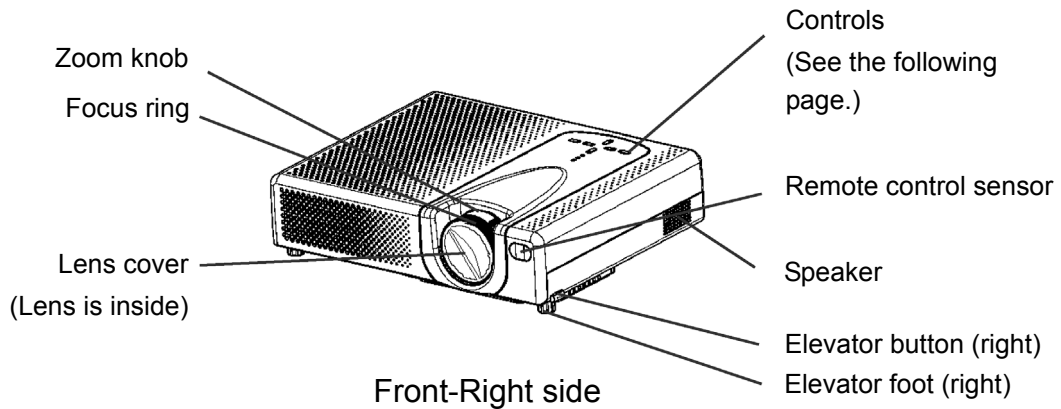

NOTE (*) About Restart switch: This Projector is controlled by an internal microprocessor. Under certain exceptional circumstances, the projector may not operate correctly and the microprocessor will need to be reset. In such a case, please push the Restart switch by using a cocktail stick or similar and the projector will restart. Only push the Restart switch in these exceptional instances.

Part names

Projector

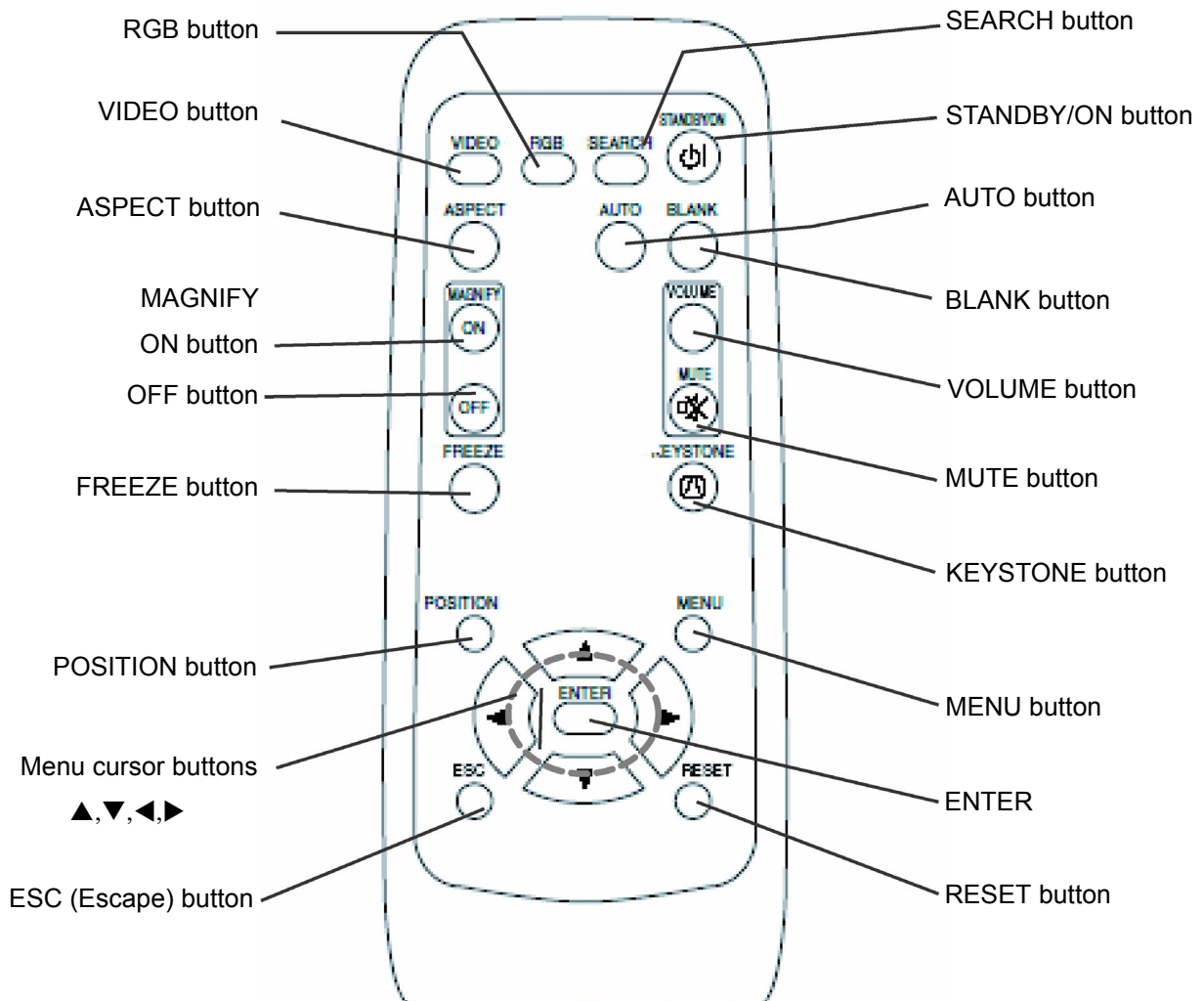
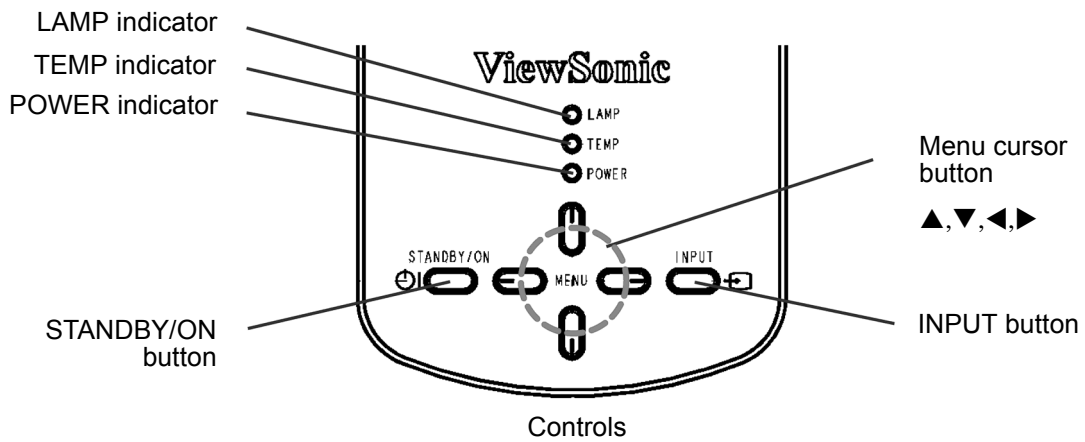

Setting up

WARNING

► Place the projector in a stable position horizontally. A fall or a turnover could cause an injury and/or damage to the projector. Then using a damaged projector could result in a fire and/or an electric shock.

* Don't place the projector on an unstable, slanted or vibrating surface such as a wobbly or inclined stand.

* Do not place the projector in the side/front/rear-up position, except for care of the air filter.

* For the projector installed bottom-up, use the accessory filter cover for bottom-up use. And in the case of a ceiling installation or the like, contact your dealer before installation.

► Place the projector in a cool place, and pay attention enough to ventilation. The high temperature of the projector could cause a fire, a burn and/or malfunction to the projector.

* Don't stop up, block and cover the projector's vents.

* Keep a space of 30 cm or more between the sides and other objects such as walls.

* Don't place the projector on a metallic thing or anything weak in heat.

* Don't place the projector on a carpet, cushion or bedding.

* Don't place the projector in direct sunlight or near a hot object such as heater.

* Put nothing about lens and vents of the projector. Put nothing on the projector.

* Put nothing that is sucked or sticks to the bottom of projector. This projector also has additional intake vents also on the bottom.

► Do not place the projector on the place that gets wet. Damping the projector or inserting liquid in the projector could cause a fire, an electric shock and/or malfunction to the projector.

* Don't place the projector in a bathroom or the outdoors.

* Put nothing containing the liquid near the projector.

CAUTION

► Avoid a smoky, humid or dusty place. Placing the projector in such place could cause a fire, an electric shock and/or malfunction to the projector.

* Don't place the projector near a humidifier, a smoking space or a kitchen.

* Put nothing containing the liquid near the projector.

Arrangement

Refer to the illustrations and tables below to determine the screen size and projection distance.

The values shown in the table are calculated for a full size screen: 1280 x 720

- (a) The screen size (diagonal)
- (b) Distance from the projector to the screen ($\pm 10\%$)
- (c) The height of the screen ($\pm 10\%$)

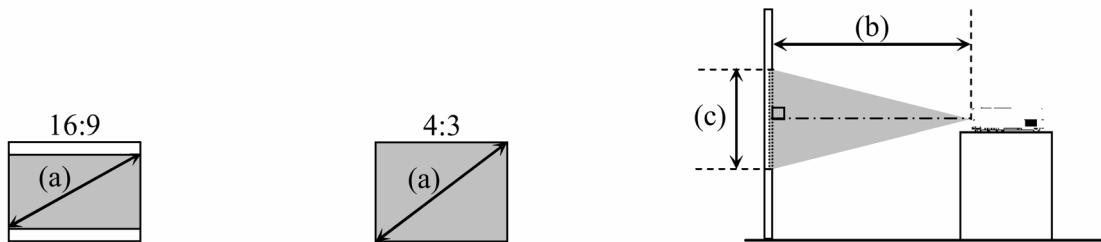

At 4:3 screen

(a) Screen size [inch (m)]		(b) Projection distance				(c) Screen height [inch (cm)]	
		min		max			
30	(0.8)	35	(0.9)	42	(1.1)	2	(5)
40	(1.0)	47	(1.2)	56	(1.4)	2	(6)
50	(1.3)	59	(1.5)	71	(1.8)	3	(8)
60	(1.5)	72	(1.8)	85	(2.2)	4	(9)
70	(1.8)	84	(2.1)	100	(2.5)	4	(11)
80	(2.0)	96	(2.4)	114	(2.9)	5	(12)
90	(2.3)	108	(2.7)	129	(3.3)	5	(14)
100	(2.5)	120	(3.1)	143	(3.6)	6	(15)
120	(3.0)	144	(3.7)	172	(4.4)	7	(18)
150	(3.8)	181	(4.6)	216	(5.5)	9	(23)
200	(5.1)	242	(6.1)	288	(7.3)	12	(30)
250	(6.4)	303	(7.7)	361	(9.2)	15	(38)
300	(7.6)	363	(9.2)	433	(11.0)	18	(46)

At 16:9 screen

(a) Screen size [inch (m)]		(b) Projection distance				(c) Screen height [inch (cm)]	
		min		max			
30	(0.8)	38	(1.0)	46	(1.2)	0	(-1)
40	(1.0)	52	(1.3)	62	(1.6)	-1	(-2)
50	(1.3)	65	(1.6)	77	(2.0)	-1	(-2)
60	(1.5)	78	(2.0)	93	(2.4)	-1	(-2)
70	(1.8)	91	(2.3)	109	(2.8)	-1	(-3)
80	(2.0)	105	(2.7)	125	(3.2)	-1	(-3)
90	(2.3)	118	(3.0)	140	(3.6)	-1	(-4)
100	(2.5)	131	(3.3)	156	(4.0)	-2	(-4)
120	(3.0)	158	(4.0)	188	(4.8)	-2	(-5)
150	(3.8)	197	(5.0)	235	(6.0)	-2	(-6)
200	(5.1)	264	(6.7)	314	(8.0)	-3	(-8)
250	(6.4)	330	(8.4)	393	(10.0)	-4	(-10)
300	(7.6)	396	(10.1)	472	(12.0)	-5	(-12)

Adjusting the projector's elevator

⚠ WARNING

▶ Do not adjust the projector's elevator during use or immediately after use. Handling while the projector is in a high temperature could cause a burn and/or malfunction to the projector.

⚠ CAUTION

▶ If you press the elevator button without holding the projector, the projector might crash down, overturn, smash your fingers and possibly result in malfunction. To prevent damaging the projector and injuring yourself, always hold the projector whenever using the elevator buttons to adjust the elevator feet.

▶ Except for inclining by the elevator feet adjustment, place the projector horizontally.

You can use the elevator feet to make adjustments if the surface on which you need to set the projector is uneven or if you otherwise need to adjust the angle of projection. The adjustment range of the elevator feet is 0 to 9 degrees.

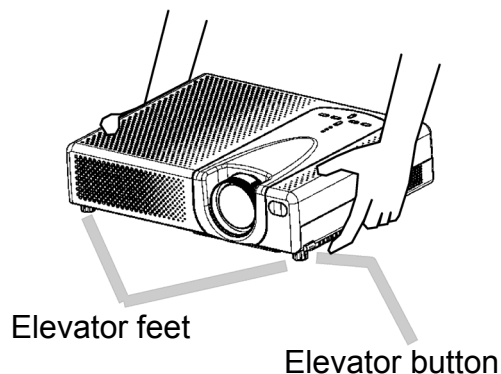

1. After making sure that the projector is cool adequately, press and hold in the elevator buttons while holding the projector.
The elevator buttons and the elevator feet are on the both sides.
2. Raise or lower the projector to the desired height and then release the elevator buttons.
When you release the elevator buttons, the elevator feet will lock into position.
3. As necessary, you can also finely adjust the height of the projector by twisting the elevator feet by hand.

About the filter cover for a unit installed bottom side up

WARNING

► Do not replace the filter cover during use or immediately after use. While the projector is connected to a power supply or is in a high temperature state, handling the projector could cause electric shock, a fire, a burn and/or malfunction to the projector.

Before handling, make sure the power switch is off and the power cord is not plugged in, then wait at least 45 minutes.

When the projector is installed bottom up, please use the accessory filter cover for bottom-up use. It is higher than usual filter cover, to keep the space for intake ventilation. Please change in the following procedure.

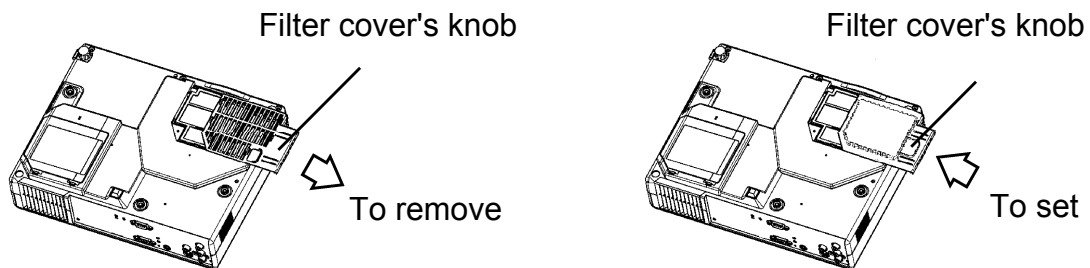

1. After making sure that the projector is adequately cool, carefully turn over the projector over so the bottom is facing up.
2. While sliding it in the direction of the arrow and removing, put a finger on the filter cover knob.
3. Replace the filter cover for bottom-up use and snap it back into place.
4. Slowly turn up the projector so that the top is facing up.

Connecting your devices

CAUTION

- ▶ Turn off all devices prior to connecting them to the projector. Attempting to connect a live device to the projector may generate extremely loud noises or other abnormalities that may result in malfunction and/or damage to the device and/or projector.
- ▶ Use the accessory cable or a designated-type cable for the connection. Some cables have to be used with core set. A cable that is too long may cause a certain picture degradation. Please consult with your dealer for details. For cables that have a core only at one end, connect the core to the projector.
- ▶ Make sure that you connect devices to the correct port. Incorrect connection may result in malfunction and/or damage to the device and/or projector.

NOTE . Whenever attempting to connect a laptop computer to the projector, be sure to activate the laptop's RGB external image output (set the laptop to CRT display or to simultaneous LCD and CRT display). For details on how this is done, please refer to the instruction manual of the corresponding laptop computer.

- Secure the screws on the connectors and tighten.
- Some computers may have multiple display screen modes. Use of some of these modes will not be possible with this projector.
- For some RGB input modes, the optional Mac adapter is necessary.
- When the image resolution is changed on a computer, depending on an input, automatic adjust function may take some time and may not be completed. In this case, you may not be able to see a check box to select "Yes/No" for the new resolution on Windows. Then the resolution will go back to the original. It might be recommended to use other CRT or TFT monitors to change the resolution.

About Plug-and-Play capability

Plug-and-Play is a system composed of the computer, its operating system and peripheral equipment (i.e. display devices). This projector is compatible with VESA DDC 2B. Plug-and-Play can be achieved by connecting this projector to computers that are VESA DDC (display data channel) compatible.

- Please take advantage of this function by connecting the accessory RGB cable to the RGB port (DDC 2B compatible). Plug-and-Play may not work properly if any other type of connection is attempted.
- Please use the standard drivers in your computer as this projector is a Plug-and-Play monitor.

With a computer

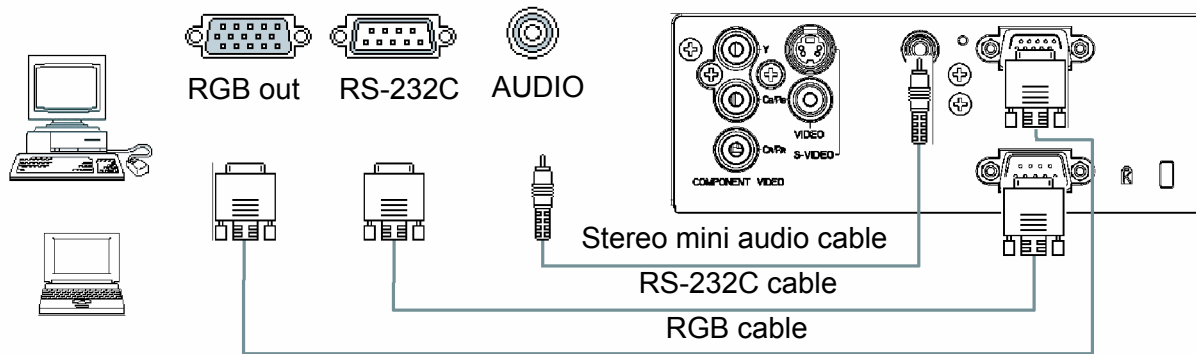

With a VCR/DVD player

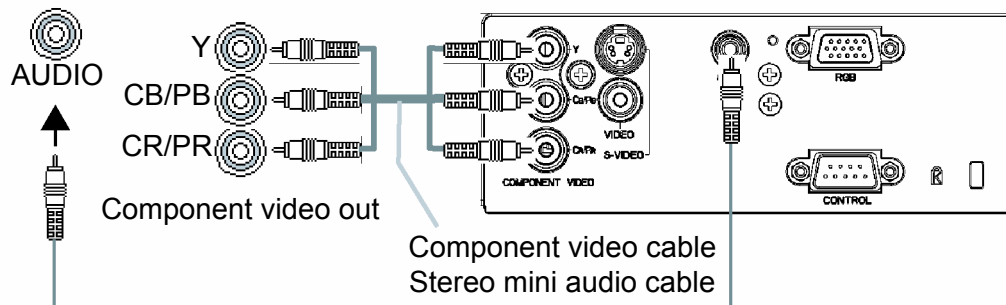
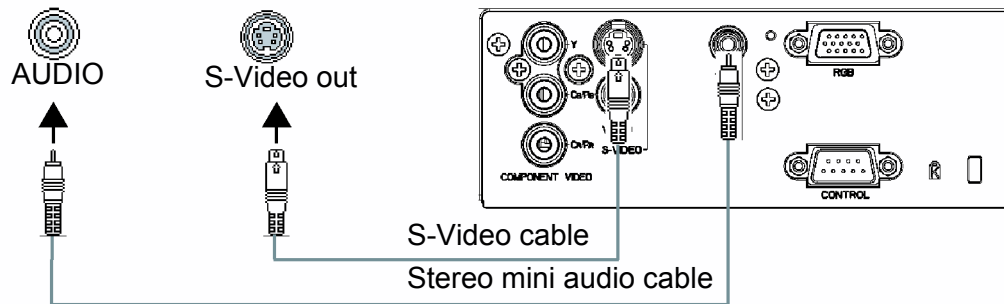
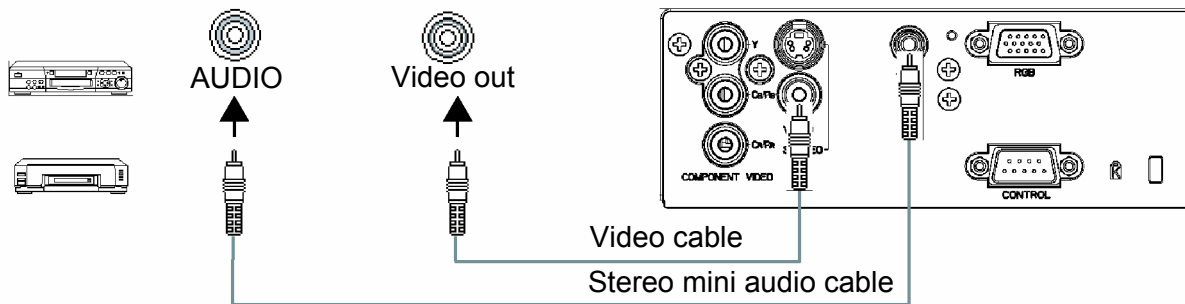

Connecting power supply

WARNING

► Please use extra caution when connecting the power cord as incorrect or faulty connections may result in fire and/or electrical shock.

* Only use the power cord that came with the projector. If it is damaged, contact your dealer to newly get correct one.

* Only plug the power cord into an outlet rated for use with the power cord's specified voltage range.

* Never modify the power cord. Never attempt to defeat the ground connection of the three-pronged plug.

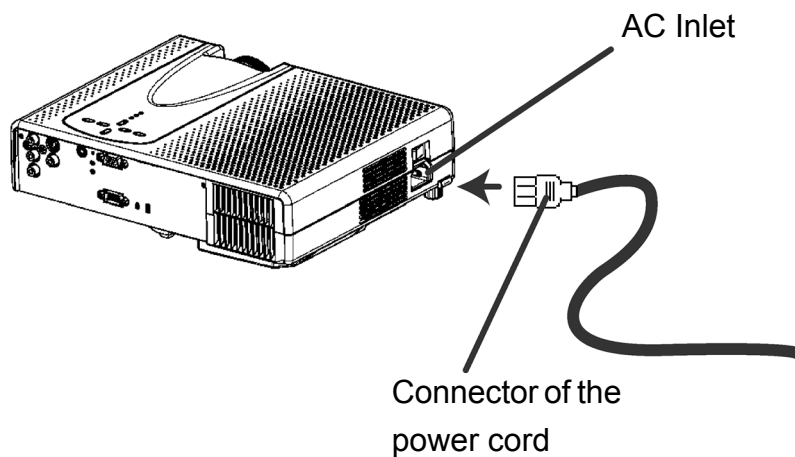

1. Connect the connector of the power cord to the AC inlet of the projector.
2. Firmly plug the power cord's plug into the outlet.

Remote control

Putting Batteries

WARNING

► Always handle the batteries with care and use them only as directed. Improper use may result in battery explosion, cracking or leakage, which could result in fire, injury and/or pollution of the surrounding environment.

* Be sure to use only the batteries specified. Do not use batteries of different types at the same time. Do not mix a new battery with used one.

* Make sure the plus and minus terminals are correctly aligned when loading a battery.

* Keep a battery away from children and pets.

* Do not recharge, short circuit, solder or disassemble a battery.

* Do not allow a battery in a fire or water. Keep batteries in a dark, cool and dry place.

* If you observe a leakage of a battery, wipe out the residue and then replace a battery. If the residue adheres your body or clothes, rinse well with water immediately.

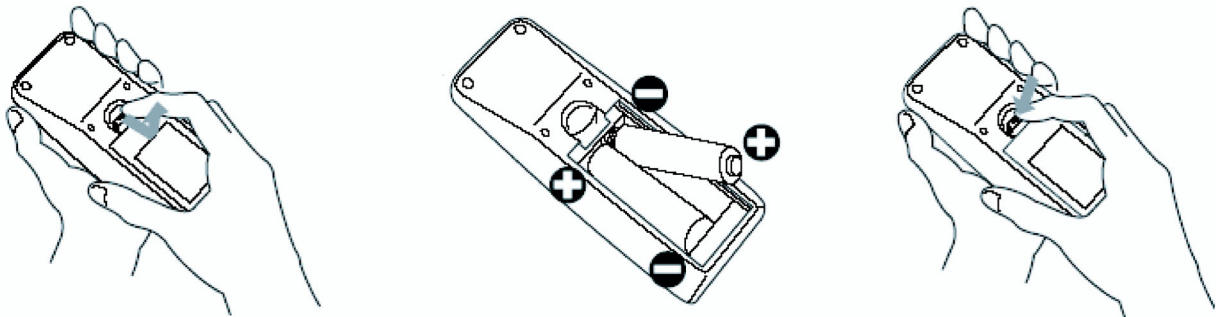

1. Remove the battery cover.

Slide back and remove the battery cover in the direction of the arrow.

2. Insert the batteries.

Align and insert the two AA batteries according to their plus and minus terminals as indicated in the remote control.

3. Close the battery cover.

Replace the battery cover in the direction of the arrow and snap it back into place.

Operating the remote control

CAUTION

- ▶ Be careful in handling the remote control.
- * Do not drop or otherwise expose the remote control to physical impact.
- * Do not get the remote control wet or place it on wet objects. Doing so may result in malfunction.
- * Remove the batteries from the remote control and store them in a safe place if you won't be using the remote control for an extended period.
- * Replace the batteries whenever the remote control starts to malfunction.
- * When strong lights, such as direct sunlight or light from an extremely close range (such as from an inverter fluorescent lamp), hit the projector's remote sensor, the remote control may cease to function. Adjust the direction of the projector to keep light from directly hitting the projector's remote sensor.

The remote control works with the projector's remote sensor.

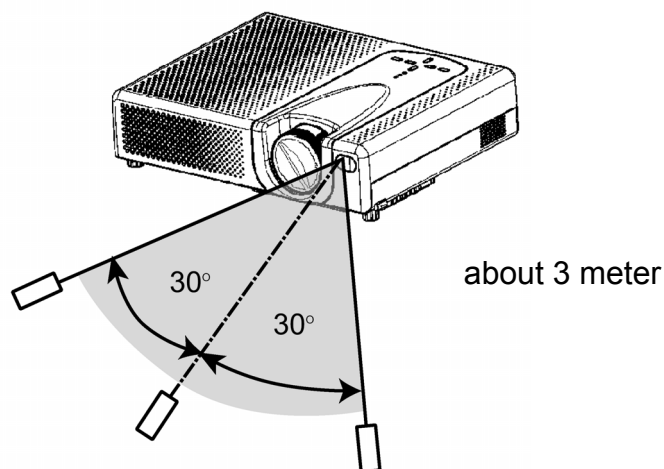

- The range of the remote sensor is 3 meters with a 60-degree range (30 degrees to the left and right of the remote sensor).
- Also a remote signal reflected in the screen etc. may be available. If it is difficult to send a remote signal to the sensor directly, please try.
- Since the remote control uses infrared light to send signals to the projector (Class1 LED), be sure to use the remote control in an area free from obstacles that could block the remote control's output signal to the projector.

Power on/off

WARNING

► When the power is on, a strong light is emitted. Do not look into the lens or vents of the projector.

NOTE. Turn the power on/off in right order. Please power on the projector before the connected devices. Power off the projector after the connected devices

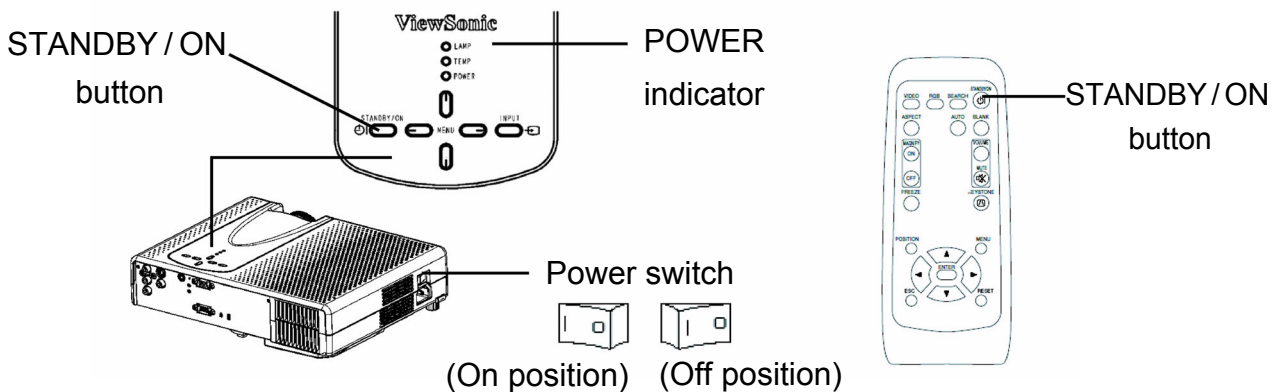

Turning on the power

1. Make sure that the power cord is firmly and correctly connected to the projector and outlet.
2. Remove the lens cover, and set the power switch to the ON position.
The power indicator will light to solid orange. Then wait several seconds because buttons may not function for these several seconds.
3. Press the STANDBY/ON (on the projector or the remote control) button.
The projector lamp will light up and the POWER indicator will begin blinking green.
When the power is completely on, the indicator will stop blinking light green.
To display the picture, select an input signal according to the section “Selecting an input signal”.

Turning off the power

1. Press the STANDBY/ON (on the projector or the remote control) button.
The message “Power off?” will appear on the screen for approximately 5 seconds.
2. Press the STANDBY/ON (on the projector or the remote control) button again while the message is visible.
The projector lamp will go off, and the POWER indicator will begin blinking orange.
Then the POWER indicator will stop blinking and light to solid orange when the lamp cooling is complete.
3. Make sure that the power indicator lights to solid orange, set the power switch to the OFF position. The POWER indicator will go off.

Operating

Adjusting the volume

1. Press the VOLUME button on the remote control.

A dialog will appear on the screen to aid you in adjusting the volume.

2. Use the menu cursor buttons ▲/▼ to adjust the volume.

To close the dialog and complete the operation, press the VOLUME button again.

Even if you don't do anything, the dialog will automatically disappear after a few seconds.

Temporarily muting the sound

1. Press the MUTE button on the remote control.

A dialog will appear on the screen indicating that you have muted the sound. If you don't do anything, the dialog will automatically disappear after a few seconds.

To restore the sound, press the MUTE button or the VOLUME button.

Selecting an input signal

1. Press the INPUT button on the projector.

Each time you press the button, the projector switches its input as below.

RGB ⇒ COMPONENT VIDEO ⇒ S-VIDEO ⇒ VIDEO

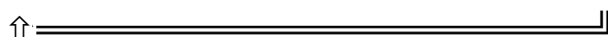

2. Press the RGB button on the remote control to select the RGB input.

RGB button ⇒ RGB

* When the TURN ON is selected to the item SEARCH of OPTION menu, if no input is detected at the RGB port, projector will begin to check other ports. Please refer to the item SEARCH of section OPTION menu.

3. Press the VIDEO button on the remote control to select a video input.

Each time you press the button, the projector switches its video input as below.

COMPONENT VIDEO ⇒ S-VIDEO ⇒ VIDEO



* When the TURN ON is selected to the item SEARCH of OPTION menu, the projector selects the COMPONENT VIDEO port at first. If no input is detected at the COMPONENT VIDEO port, projector will begin to check other ports. Please refer to the item SEARCH of section OPTION menu.

Searching an input signal

1. Press the SEARCH button on the remote control.

The projector will begin to check its input ports in order to find any input signals. Then when an input is found, the projector will stop searching and display the image. If no signal is found, the projector will return to the state selected before the operation.

RGB ⇒ COMPONENT VIDEO ⇒ S-VIDEO ⇒ VIDEO

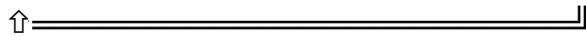

Selecting an aspect ratio

1. Press the ASPECT button on the remote control.

Each time you press the button, the projector switches the modes for aspect ratio in turn.

At a RGB signal

NORMAL ⇒ 4:3 ⇒ 16:9

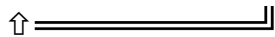

At a COMPONENT VIDEO, S-VIDEO or VIDEO signal or No signal

4:3 ⇒ 16:9 ⇒ SMALL

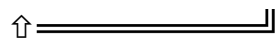

- * The NORMAL mode keeps the original aspect ratio of the signal.
- * At a HDTV signal of 1125i or 750p of COMPONENT VIDEO input, only 16:9 mode can be selected.
- * Performing the automatic adjustment initializes the aspect ratio setting.

Adjusting the zoom and focus

1. Use the zoom knob to adjust the screen size.
2. Use the focus ring to focus on the picture.

Using the automatic adjustment feature

1. Press the AUTO button on the remote control.

At a RGB signal

The vertical position, the horizontal position, the clock phase and horizontal size will be automatically adjusted.

Make sure that the application window is set to its maximum size prior to attempting to use this feature. A dark picture may still be incorrectly adjusted. Use a bright picture when adjusting.

At a COMPONENT VIDEO, S-VIDEO or VIDEO signal

The video format best suited for the respective input signal will be selected automatically. This function is available only when the AUTO mode is selected to the item VIDEO FORMAT of INPUT menu. For a component video signal, the signal type is automatically identified independently of this function.

- * The automatic adjustment operation requires approximately 10 seconds. Also please note that it may not function correctly with some input.

Adjusting the position

1. Press the POSITION button on the remote control.

The "POSITION" indication will appear on the screen.

2. Use the menu cursor buttons ▲/▼/◀/▶ to adjust the picture position.

When you want to reset the operation, press the RESET button on the remote control during the operation.

To complete this operation, press the POSITION button again.

Even if you don't do anything, the dialog will automatically disappear after a few seconds.

- * This function is available only for RGB input.

Correcting the keystone distortions

1. Press the KEYSTONE button on the remote control.

A dialog will appear on the screen to aid you in correcting the distortion.

2. Use the menu cursor buttons ▲/▼ to correct the distortion.

To close the dialog and complete this operation, press the KEYSTONE button again.

Even if you don't do anything, the dialog will automatically disappear after a few seconds.

- * This function may not work well with some input.
- * The adjustable range for correcting will vary among inputs.

Using the magnify feature

1. Press the ON button of MAGNIFY on the remote control.

The "MAGNIFY" indication will appear on the screen, and the projector will enter the MAGNIFY mode.

2. Use the menu cursor buttons ▲/▼ to adjust the zoom level.

To move the zoom area, press the POSITION button in the MAGNIFY mode, then use the menu cursor buttons ▲/▼/◀/▶ to move the area. And to finalize the zoom area, press the POSITION button again.

To exit the MAGNIFY mode and restore the screen to normal, press the OFF button of MAGNIFY on the remote control.

- * The projector automatically exits the MAGNIFY mode when the input signal changes, or when an operation of changing the display condition (automatic adjustment, etc.) is executed.
- * Although in the MAGNIFY mode, the keystone distortion condition may vary, it will be restored when the projector exits the MAGNIFY mode.

Freezing the screen

- 1 Press the FREEZE button on the remote control.

The "FREEZE" indication will appear on the screen, and the projector will enter the FREEZE mode.

To exit the FREEZE mode and restore the screen to normal, press the FREEZE button again.

- * The projector automatically exits the FREEZE mode when the input signal changes, or when one of the projector's buttons or the remote control buttons of STANDBY/ON, SEARCH, RGB, VIDEO, BLANK, AUTO, VOLUME, MUTE, POSITION and MENU is pressed.
- * If the projector continues projecting a still image for long time, the LCD panel might possibly be printed. Do not leave the projector in FREEZE mode for too long.

Temporarily blanking the screen

1. Press the BLANK button on the remote control.

The blank screen (refer to the item BLANK of section SCREEN menu) will be displayed instead of the screen of input signal.

To remove the blank screen and return to the input signal screen, press the BLANK button again.

- * The projector automatically returns to the input signal screen when the input signal changes, or when one of the projector's buttons or the remote control buttons of STANDBY/ON, SEARCH, RGB, VIDEO, FREEZE, AUTO, VOLUME, MUTE, POSITION and MENU is pressed.

Multifunctional setting

Using the menu function

This projector has the following menus: PICTURE, IMAGE, INPUT, SETUP, SCREEN, OPTION and EASY MENU. Each of these menus is operated using the same methods. The basic operations of these menus are as follows.

1. Press the MENU button on the remote control or one of the menu cursor buttons on the projector.

The advanced MENU or EASY MENU will appear.

2. Use the menu cursor buttons ▲/▼ to select a menu.

At the EASY MENU

If you want to change it to the advanced MENU, select the "Go to Advanced Menu".

At the advanced MENU

Select a menu of PICTURE, IMAGE, INPUT, SETUP, SCREEN or OPTION.

If you want to change it to the EASY MENU, select the EASY MENU.

3. Then press the menu cursor button ► or the ENTER button on the remote control to progress.

The display of the selected menu will be active.

4. Use the menu cursor buttons ▲/▼ to select an item to operate. Then press the menu cursor button ► or the ENTER button on the remote control to progress.

The operation menu of the selected item will appear.

5. Use the cursor buttons ▲/▼ to operate the item.

When you want to reset the operation, press the RESET button on the remote control during the operation. Note that items whose functions are performed simultaneously with operation (ex. LANGUAGE, H PHASE etc.) aren't reset.

When you want to return to the previous display, press the cursor button ◀.

6. Press the MENU button on the remote control again to close the menu and complete this operation.

Even if you don't do anything, the dialog will automatically disappear after about 10 seconds.

EASY MENU

With the EASY MENU, items shown in the table below can be performed. Select an item using the menu cursor buttons ▲/▼, and press the menu cursor button ► or the ENTER button on the remote control to progress. Then perform it referring to the following table.

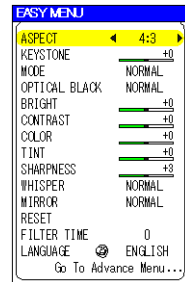

Item	Description
ASPECT	Using the buttons ◀/▶ switches the mode for aspect ratio. See the item ASPECT of section IMAGE menu.
KEYSTONE	Using the buttons ◀/▶ corrects the keystone distortion. See the item KEYSTONE of section SETUP menu.
MODE	Using the buttons ◀/▶ switches the mode of picture type. The modes of picture type are combinations of a mode of GAMMA and a mode of COLOR TEMP. Choose a suitable mode according to the projected source. NORMAL ⇔ CINEMA ⇔ DYNAMIC ↑=====↑ NORMAL: (COLOR TEMP = MIDDLE) + (GAMMA = #1 DEFAULT) CINEMA: (COLOR TEMP = LOW) + (GAMMA = #2 DEFAULT) DYNAMIC: (COLOR TEMP = HIGH) + (GAMMA = #3 DEFAULT) * When the combination of GAMMA and COLOR TEMP differs from pre-assigned modes above, the display on the menu for the MODE is "CUSTOM". Please refer to the items GAMMA and COLOR TEMP of PICTURE menu.
BRIGHT	Using the buttons ◀/▶ adjusts the brightness. See the item BRIGHT of section PICTURE menu.
CONTRAST	Using the buttons ◀/▶ adjusts the contrast. See the item CONTRAST of section PICTURE menu.
COLOR	Using the buttons ◀/▶ adjusts the strength of whole color. See the item COLOR of section PICTURE menu.
TINT	Using the buttons ◀/▶ adjusts the tint. See the item TINT of section PICTURE menu.
SHRPNNESS	Using the buttons ◀/▶ adjusts the sharpness. See the item SHARPNESS of section PICTURE menu.
WHISPER	Using the buttons ◀/▶ turns off/on the whisper mode. See the item WHISPER of section SETUP menu.
MIRROR	Using the buttons ◀/▶ switches the mode for mirror status. See the item MIRROR of section SETUP menu.
RESET	Performing this item resets all of the items of EASY MENU except, FILTER TIME and LANGUAGE. A dialog is displayed to make sure. Selecting RESET using the button ▲ performs reset.
FILTER TIME	Performing this item resets the filter timer (it counts use time of air filter). A dialog is displayed to make sure. Selecting RESET using the button ▲ performs reset. (The same as the item FILTER TIME of OPTION menu.)
LANGUAGE	Select the LANGUAGE to toggle the menu language. Refer to description of LANGUAGE in the SCREEN menu.
Go To Advanced Menu	Select the "Go To Advanced Menu" to use the menu of PICTURE, IMAGE, INPUT, SETUP, SCREEN or OPTION.

PICTURE menu

With the PICTURE menu, items shown in the table below can be performed.

Select an item using the menu cursor buttons ▲/▼, and press the menu cursor button ► or the ENTER button on the remote control to progress.

Then perform it referring to the following table.

MENU [RGB]		SELECT
PICTURE	BRIGHT	+ 0
IMAGE	CONTRAST	+ 0
INPUT	GAMMA	#1 DEFAULT
SETUP	COLOR TEMP	6500K
SCREEN	COLOR	+ 0
OPTION	TINT	+ 0
EASY MENU	SHARPNESS	+ 0
	PROGRESSIVE	TURN OFF
	MY MEMORY	SAVE 1

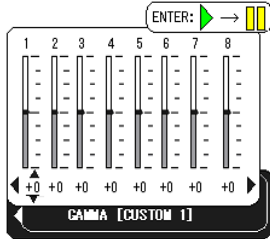
Item	Description
BRIGHT	Using the buttons ▲/▼ adjusts the brightness. Light ⇔ Dark
CONTRAST	Using the buttons ▲/▼ adjusts the contrast. Strong ⇔ Weak
GAMMA	Using the buttons ▲/▼ switches the GAMMA mode. #1 DEFAULT ⇔ #1 CUSTOM ⇔ #2 DEFAULT ⇕ #2 CUSTOM ⇔ #3 DEFAULT ⇔ #2 CUSTOM To adjust #1 CUSTOM, #2 CUSTOM or #3 CUSTOM Selecting a mode of CUSTOM and then pressing the button ► or the ENTER button on the remote control displays a dialog to aid you in adjusting the mode. This function is useful when you want to change the brightness of each tone level individually.  Choose an item using the buttons ◀/▶, and adjust the level using the buttons ▲/▼. You can display a test pattern for checking the effect of your adjustment by pressing the ENTER button on the remote control. Each time you press the ENTER button, the pattern changes as below. No pattern ⇔ Gray scale of 9 steps ⇕ Ramp ⇔ Gray scale of 15 steps Eight of equalizing bars corresponds to eight of tone level of test pattern except the darkest in the left end. If you want to adjust the 2nd tone from left end on the test pattern, use the equalizing adjustment bar “1”. The darkest tone at the left end of the test pattern cannot be controlled with any of equalizing adjustment bar.

<p>COLOR TEMP</p>	<p>Using the buttons ▲/▼ switches the mode of color temperature. HIGH ⇔ MIDDLE ⇔ LOW ⇔ CUSTOM ↑=====↑</p> <p>To adjust CUSTOM Selecting the CUSTOM and then pressing the button ► or the ENTER button on the remote control displays a dialog to aid you in adjusting the OFFSET and/or GAIN of CUSTOM mode. OFFSET adjustments change the color intensity on the whole tones of the test pattern. GAIN adjustments mainly affect color intensity on the brighter tones of the test pattern</p>  <p>Choose an item using the buttons ◀/▶, and adjust the level using the buttons ▲/▼. You can display a test pattern for checking the effect of your adjustment by pressing the ENTER button on the remote control. Each time you press the ENTER button, the pattern changes as below.</p> <p>No pattern ⇒ Gray scale of 9 steps ↑ ↓ Ramp ⇔ Gray scale of 15 steps</p>
<p>COLOR</p>	<p>Using the buttons ▲/▼ adjusts the strength of whole color. Strong ⇔ Weak * This item can be selected only at a video input. (except for SECAM signal.)</p>
<p>TINT</p>	<p>Using the buttons ▲/▼ adjusts the tint. Green ⇔ Red * This item can be selected only at a video input.</p>
<p>SHARPNESS</p>	<p>Using the buttons ▲/▼ adjusts the sharpness. Strong ⇔ Weak</p>
<p>PROGRESSIVE</p>	<p>Using the buttons ▲/▼ switches the progressive mode. TV ⇔ FILM ⇔ TURN OFF ↑=====↑</p> <p>* This function performs only at an interlaced signal of a VIDEO input, a S-VIDEO input or a COMPONENT VIDEO input of 525i (480i) or 625 (576i) signal. * When the TURN ON is selected, the screen image will be crisper. But it may cause a certain defect (for example, jagged line) of the picture at a quick moving object. In such a case, please select the TURN OFF, even though the screen image may lose the crisp. * This function may cause a certain degradation of the picture. In such a case, please select the TURN OFF.</p>
<p>MY MEMORY</p>	<p>Selecting a mode of MY MEMORY using the buttons ▲/▼ and then pressing the button ► or the ENTER button on the remote control performs each function. LOAD1 ⇔ LOAD2 ⇔ LOAD3 ⇔ LOAD4 ↑ ↓ SAVE4 ⇔ SAVE3 ⇔ SAVE2 ⇔ SAVE1 This projector has 4 numbered memories for adjustment data. Performing the LOAD1, LOAD2, LOAD3 or LOAD4 loads the data on the memory whose number corresponds with the command's number, and adjusts the picture automatically depending on the data. Performing the SAVE1, SAVE2, SAVE3 or SAVE4 puts the current adjustment data on the memory whose number corresponds with the command's number.</p>

IMAGE menu

With the IMAGE menu, items shown in the table below can be performed.

Select an item using the menu cursor buttons ▲/▼, and press the menu cursor button ► or the ENTER button on the remote control to progress.

Then perform it referring to the following table.

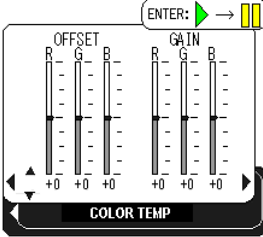
MENU [RGB]		SELECT
PICTURE	ASPECT	4:3
IMAGE	OVER SCAN	95
INPUT	V POSITION	25
SETUP	H POSITION	142
SCREEN	H PHASE	18
OPTION	H SIZE	1344
EASY MENU	AUTO ADJUST	

Item	Description
ASPECT	<p>Using the buttons ▲/▼ switches the mode for aspect ratio.</p> <p>At a RGB signal 4:3 ⇔ 16:9 ⇔ NORMAL ↑=====↑</p> <p>At a COMPONENT VIDEO, S-VIDEO, VIDEO signal or No signa 4:3 ⇔ 16:9 ⇔ SMALL ↑=====↑</p> <p>* The NORMAL mode keeps the original aspect ratio of the signal. * At a RGB input, selecting an aspect ratio may display the message "SYNC IS OUT OF RANGE". In this case, please use one of other aspect ratio mode. * At a HDTV signal of 1125i (1080i) or 750p (720p) of COMPONENT VIDEO input, only 16:9 mode can be selected. * Performing the automatic adjustment initializes the aspect ratio setting.</p>
OVER SCAN	<p>Using the buttons ▲/▼ adjusts the over-scan ratio. Large (It reduces picture) . Small (It magnifies picture)</p> <p>* This item can not be selected only at a video RGB input. * When this adjustment is too large, certain degradation may appear at the frame area of the picture. In such a case, please adjust small.</p>
V POSITION	<p>Using the buttons ▲/▼ adjusts the vertical position. Up ⇔ Down</p>
H POSITION	<p>Using the buttons ▲/▼ adjusts the horizontal position. Left ⇔ Right</p>
H PHASE	<p>Using the buttons ▲/▼ adjusts the horizontal phase to eliminate flicker. Up ⇔ Down</p> <p>* This item can be selected only at a RGB input and a Component video input.</p>
H SIZE	<p>Using the buttons ▲/▼ adjusts the horizontal size. Large ⇔ Small</p> <p>* This item can be selected only at a RGB input. * When this adjustment is excessive, the picture may not be displayed correctly. In such a case, please reset the adjustment pressing the RESET button on the remote control during this operation.</p>
AUTO ADJUST	<p>Selecting this item performs the automatic adjustment feature.</p> <p>At a RGB signal The vertical position, the horizontal position, the clock phase and horizontal size will be automatically adjusted. Make sure that the application window is set to its maximum size prior to attempting to use this feature. A dark picture may still be incorrectly adjusted. Use a bright picture when adjusting.</p> <p>At a COMPONENT VIDEO, S-VIDEO or VIDEO signal The video format best suited for the respective input signal will be selected automatically. This function is available only when the AUTO mode is selected to the item VIDEO FORMAT of INPUT menu. For a component video signal, the signal type is identified automatically independently of this function. * The automatic adjustment operation requires approximately 10 seconds. Also please note that it may not function correctly with some input.</p>

SETUP menu

With the SETUP menu, items shown in the table below can be performed.

Select an item using the menu cursor buttons ▲/▼, and press the menu cursor button ► or the ENTER button on the remote control to progress.

Then perform it referring to the following table.

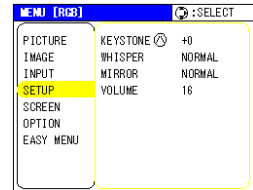

Item	Description
KEYSTONE	Using the buttons ▲/▼ corrects the keystone distortion. Upper in the data ⇔ Lower in the data * The adjustable range of this function will vary with the type of input signal. At some signals, this function may not work well. * When the V:INVERT or the H&V:INVERT is selected under the item MIRROR, if the projector screen is inclined or if the projector is angled downward, this function may not work correctly. * When the zoom adjustment is set to the TELE side, this correction may be excessive. This function should be used with zoom set to WIDE whenever possible.
WHISPER	Using the buttons ▲/▼ turns off/on the whisper mode. NORMAL ⇔ WHISPER * When the WHISPER is selected, acoustic noise and screen brightness are reduced.
MIRROR	Using the buttons ▲/▼ switches the mode for mirror status. NORMAL ⇔ H:INVERT ⇔ V:INVERT ⇔ H&V:INVERT ↑=====↑
VOLUME	Using the buttons ▲/▼ adjusts the volume. High ⇔ Low

SCREEN menu

With the SCREEN menu, items shown in the table below can be performed.

Select an item using the menu cursor buttons ▲/▼, and press the menu cursor button ► or the ENTER button on the remote control to progress.

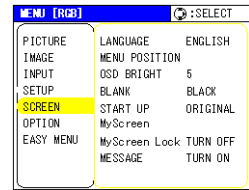

Then perform it referring to the following table.

Item	Description
LANGUAGE	Using the buttons ▲/▼ switches the OSD (On Screen Display) language. ENGLISH⇔FRANÇAIS⇔DEUTSCH⇔ESPAÑO⇔ITALIANO ↑ ↓=====↑ NORSK⇔NEDERLANDS⇔PORTUGUÊS⇔日本語⇔中文 ↓=====↑ 한글⇔SVENSKA⇔PYCCKNŃ⇔SUOMI⇔POLSKI L=====↑
MENU POSITION	Using the buttons ◀/▶/▲/▼ adjusts the menu position. To quit the operation, press the MENU button on the remote control or keep no operation for 10 seconds.
OSD BRIGHT	Using the buttons ▲/▼ switches the brightness level of the OSD (On Screen Display). BRIGHT ⇔ DARK
BLANK	Using the buttons ▲/▼ switches the mode the blank screen. The blank screen is the screen for the temporarily blanking feature. It is displayed by pressing the BLANK button on the remote control. MyScreen ⇔ ORIGINAL ⇔ BLUE ⇔ WHITE ⇔ BLACK MyScreen is the screen you can register a desired screen. ORIGINAL screen is the existing standard screen. BLUE, WHITE and BLACK are non-patterned (plain) screens in each color. * To avoid remaining as an afterimage, the MyScreen and the ORIGINAL screens will change to the BLACK screen after several minutes. * For the MyScreen, please refer to the item MyScreen in this table.
START UP	Using the buttons ▲/▼ switches the mode the start up screen. The start up screen is the screen displayed when no signal or an unsuitable signal is detected. MyScreen ⇔ ORIGINAL ⇔ TURN OFF MyScreen is the screen you can register a desired screen. ORIGINAL screen is the existing standard screen. When the TURN OFF is selected, the BLUE screen is used. * To avoid remaining as an afterimage, the MyScreen and the ORIGINAL screens will change to the BLANK screen after several minutes. If also the BLANK screen is the MyScreen or ORIGINAL, it will change to the BLACK screen. * For the MyScreen, please refer to the item MyScreen in this table. About the BLUE, BLACK and BLANK screens, please refer to the item BLANK in this table.

MyScreen	<p>This item functions for capturing the MyScreen of the blank screen and the start up screen. Please execute displaying the input including the picture you want to capture.</p> <ol style="list-style-type: none"> 1. Selecting this item displays a dialog titled "MyScreen". It will ask you if you start capturing the picture from the current screen. Please wait for the target picture to be displayed, and press the ENTER button on the remote control when the picture is display. The picture will freeze and the frame for capturing appears. To stop performing, press the RESET or ESC button on the remote control. 2. Using the buttons ◀/▶/▲/▼ adjust the frame position. Please move the frame to the position of the picture which you want to use. To start registration, press the ENTER button on the remote control. To restore the screen and return to the previous dialog, press the RESET or ESC button on the remote control. <p>Registration takes about two minutes. When the registration is completed, the registered screen and the message "MyScreen registration is finished." are displayed for several seconds. If the registration failed, the message "A capturing error has occurred. Please try again." is displayed.</p>
MyScreen Lock	<p>Using the buttons ▲/▼ turns on/off the MyScreen lock function. TURN ON ⇔ TURN OFF</p> <p>When the TURN ON is selected, the item MyScreen cannot be performed. Use this function for protecting the current MyScreen.</p>
MESSAGE	<p>Using the buttons ▲/▼ turns on/off the message function. TURN ON ⇔ TURN OFF</p> <p>When the TURN ON is selected, the following message function works. "AUTO IN PROGRESS" while automatically adjusting "NO INPUT IS DETECTED" "SYNC IS OUT OF RANGE" "Detecting...." while searching for the input The indication of the input signal by changing The indication of the aspect ration by changing</p>

OPTION menu

With the OPTION menu, items shown in the table below can be performed.

Select an item using the menu cursor buttons ▲/▼. And press the menu cursor button ► or the ENTER button on the remote control to progress, except for the items LAMP TIME and FILTER TIME. Then perform it referring to the following table.

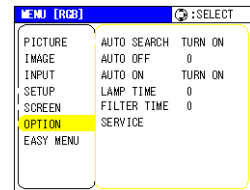







Item	Description
SEARCH	Using the buttons ▲/▼ turns on/off the message function. TURN ON ⇔ TURN OFF When the TURN ON is selected, detecting no signal automatically cycles through input ports in order of following. Then when an input is found, the projector will stop searching and display the image. If no signal is found, the projector will return to the state before the operation.
AUTO OFF	Using the buttons ▲/▼ adjusts the time to count down to automatically turn the projector off. Long (max. 99 minutes) ⇔ Short (min. 0 minute = DISABLE) When the time is set to 0, the projector is not turned off automatically. When the time is set to 1 to 99, and when the passed time with a proper signal (without no-signal and an unsuitable signal) reaches at the set time, the projector lamp will go off and the power indicator begins blinking. Please refer to the section "Turning off the power".
AUTO ON	Using the buttons ▲/▼ turns on/off the message function. TURN ON ⇔ TURN OFF When the TURN ON is selected, you can turn the projector on without pressing the STANDBY/ON button. Please refer to the section "Turning on the power". If 5 minutes passed with no signals or no keys the projector will go off.
LAMP TIME	The lamp time is the time counted after the last resetting. It is shown in the OPTION menu as the use time of the lamp. Pressing the RESET button on the remote control for about 3 second displays a dialog. To reset the lamp time, select the RESET using the button ▲. RESET ⇔ CANCEL * Please reset the lamp time only when you replace the lamp, for correct messages about the lamp. * About the lamp replacement, please see the section Lamp.
FILTER TIME	The filter time is the time counted after the last resetting. It is shown in the OPTION menu as the use time of the air filter. Pressing the RESET button on the remote control for about 3 seconds displays a dialog. To reset the filter time, select the RESET using the button ▲. RESET ⇔ CANCEL * Please reset the filter time only when you clean or replace the air filter, for correct messages about the air filter. * About the caring the sir filter, please see the section Air filter.

SERVICE	<p>Selecting this item displays the SERVICE menu. Select an item using the menu cursor buttons ▲/▼, and press the menu cursor button ► or the ENTER button on the remote control to progress.</p> <p>FAN SPEED ⇄ FACTORY RESET ⇄ GHOST</p> <p>FAN SPEED: Using the buttons ▲/▼ switches the rotation speed of the cooling fans. The HIGH is the mode for use at highlands etc. Note that the projector is noisier when the HIGH is selected.</p> <p>HIGH ⇄ NORMAL</p> <p>FACTORY RESET: Selecting “RESET” using the button ▲ performs this function. By this function, all the items in all of menu will collectively return to the initial setting. Note that the items LAMP TIME, FILTER TIME and LANGUAGE are not reset.</p> <p>RESET ⇄ CANCEL</p> <p>GHOST:</p> <ol style="list-style-type: none"> 1. Select a color element of ghost using the buttons ▲/▼ and press the menu cursor button ► or the ENTER button on the remote control to progress. 2. Adjust the selected element using the buttons ▲/▼ to disappear ghost.
---------	--

Maintenance

Lamp

<p> WARNING  HIGH VOLTAGE  HIGH TEMPERATURE  HIGH PRESSURE</p>	
<p>▶ The projector uses a high-pressure mercury glass lamp. The lamp can <u>break with a loud bang, or burn out</u>, if jolted or scratched, handled while hot, or worn over time. Note that each lamp has a different lifetime, and some may burst or burn out soon after you start using them. In addition, when the bulb bursts, it is possible for <u>shards of glass</u> to fly into the lamp housing, and for <u>gas containing mercury</u> to escape from the projector's vent holes.</p>	
<p>▶ About disposal of a lamp • This product contains a mercury lamp; do not put in trash. Dispose of in accord with environmental laws. For lamp recycling, go to www.lamprecycle.org. (in the US) For product disposal, contact your local government agency or www.eiae.org (in the US) or www.epsc.ca (in Canada). For more information, call your dealer.</p>	
<p> Disconnect the plug from the power outlet</p>	<ul style="list-style-type: none"> • If the lamp should break (it will make a loud bang when it does), unplug the power cord from the outlet, and make sure to request a replacement lamp from your local dealer. Note that shards of glass could damage the projector's internals, or cause injury during handling, so please do not try to clean the projector or replace the lamp yourself. • If the lamp should break (it will make a loud bang when it does), ventilate the room well, and make sure not to breathe the gas that comes out of the projector vents, or get it in your eyes or mouth. • Before replacing the lamp, turn the projector off and unplug the power cord, then wait at least 45 minutes for the lamp to cool sufficiently. Handling the lamp while hot can cause burns, as well as damaging the lamp.
<p></p>	<ul style="list-style-type: none"> • Never unscrew except the appointed (marked by an arrow) screws. • Do not open the lamp cover while the projector is suspended from above. This is dangerous, since if the lamp's bulb has broken, the shards will fall out when the cover is opened. In addition, working in high places is dangerous, so ask your local dealer to have the lamp replaced even if the bulb is not broken. • Do not use the projector with the lamp cover removed. At the lamp replacing, make sure that the screws are screwed in firmly. Loose screws could result in damage or injury.
<p></p>	<ul style="list-style-type: none"> • Use only the lamp of the specified type. • If the lamp breaks soon after the first time it is used, it is possible that there are electrical problems elsewhere besides the lamp. If this happens, contact your local dealer or a service representative. • Handle with care: jolting or scratching could cause the lamp bulb to burst during use. • If the indicators or a message prompts you to replace the lamp (see the section "Related Messages" and "Regarding the indicator Lamps"), replace the lamp as soon as possible. • Using the lamp for long periods of time, or past the replacement date, could cause it to burst. Do not use old (used) lamps; this is a cause of breakage.

When the indicators or a message prompts you to replace the lamp, replace the lamp as soon as possible.

- 1 Turn the projector off, and unplug the power cord. Allow the lamp to cool for at least 45 minutes.
2. To prepare a new lamp, contact your dealer and tell the lamp type number: PRJ-RLC-015 If the projector is mounted on the ceiling, or if the lamp has broken, also ask the dealer to replace the lamp.

In the case of replacement by yourself,

3. After making sure that the projector has cooled adequately, slowly turn over the projector, so that the bottom is facing up.
4. Please unhook the claws of the lamp cover using a minus screwdriver or similar, and remove the lamp cover.
5. Loosen the 2 screws (marked by arrow) of the lamp, and slowly pick up the lamp by the handles.
6. Insert the new lamp, and retighten firmly two screws that are loosened in the previous process to lock it in place.
7. Interlocking the 2 tabs of the lamp cover to the projector, position the lamp cover on the projector. Then push the center point of two claws to fix the lamp cover.
8. Slowly turn the projector so that the top is facing up.
9. Turn the projector on, and reset the lamp time using the LAMP TIME function of OPTION menu.

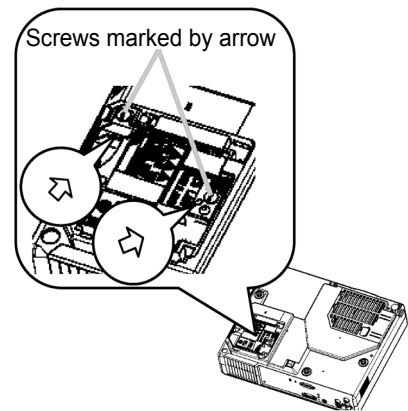
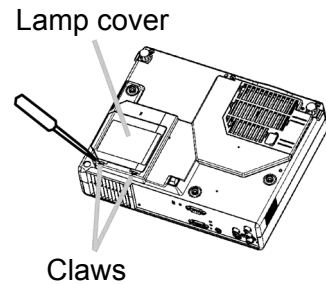

Center point of claws

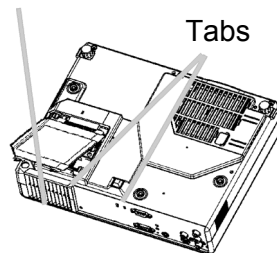

NOTE • When the lamp has been replaced after the message of “THE POWER WILL TURN OFF AFTER 0hr.” is displayed, complete the following operation within 10 minutes of switching power on.

- Incorrectly resetting of the lamp timer (resetting without replacement, or neglect of resetting after replacement) will result in incorrect message functions.

Air filter

⚠ WARNING

- ▶ Before caring, make sure the power switch is off and the power cable is not plugged in, and then allow the projector to cool sufficiently. The care in a high temperature state of the projector could cause a burn and/or malfunction to the projector.
- ▶ Use only the air filter of the specified type. Do not use the projector with the air filter and filter cover removed.
- ▶ Avoid wetting the projector or inserting liquids in the projector. It could result in a fire, an electric shock, and and/or malfunction to the projector.

⚠ CAUTION

- ▶ Please replace the air filter when it is damaged or too soiled, and also when you replace the lamp.

When the indicators or a message prompts you to clean the air filter, clean the air filter as soon as possible. If the air filter becomes clogged by dust or the like, internal temperatures rise and the power may be automatically turned off for malfunction prevention.

1. Turn the projector off, and unplug the power cord. Allow the projector to cool for at least 45 minutes. And prepare a vacuum cleaner.
2. After making sure that the projector is cool adequately, slowly turn the projector so that the lens-side is facing up. Please be careful for a projector not to fall. While the projector is placed lens-side up, hold the projector.
3. Putting a finger on the filter cover's knob, slide the filter cover in the direction of the arrow to remove it.
4. Holding the air filter's knob, pull the air filter off.
5. Slowly turn the projector bottom up.
6. Apply a vacuum cleaner to the air filter and filter cover. Please replace the air filter when it is damaged or too soiled. To prepare a new air filter, contact your dealer and or ViewSonic for the part number information.

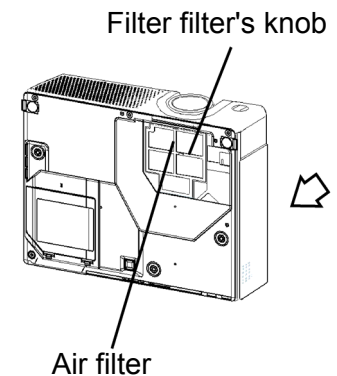
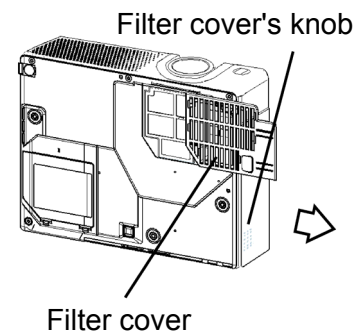

7. Position the cleaned air filter or a new air filter into place, and push the points with claws to fix the air filter.
8. Replace the filter cover and snap it back into place.
9. Slowly turn the projector so that the top is facing up.
10. Turn the projector on, and reset the filter time using the FILTER TIME function of OPTION menu.

NOTE. Incorrectly resetting of the filter timer (resetting without replacement, or neglect of resetting after replacement) will result in incorrect message functions

Other care

WARNING

- ▶ Before caring, make sure the power switch is off and the power cable is not plugged in, and then allow the projector to cool sufficiently. The care in a high temperature state of the projector could cause a burn and/or malfunction to the projector.
- ▶ Never try to care for the inside of the projector personally. Doing is so dangerous.
- ▶ Avoid wetting the projector or inserting liquids in the projector. It could result in a fire, an electric shock, and and/or malfunction to the projector.
- * Don't put a container containing water, cleaner or chemicals near the projector.
- * Don't use aerosols or sprays.

CAUTION

- ▶ Please take right care of the projector according to the following. Incorrect care could cause not only an injury but adverse influence such as discoloration, peeling paint, etc.
- * Do not use cleaner or chemicals other than those listed below.
- * Do not polish or wipe with hard objects.

Inside of the projector

In order to ensure the safe use of your projector, please have it cleaned and inspected by your dealer about once every 2 years.

Caring for the lens

If the lens is flawed, soiled or fogged, it could cause deterioration of display quality. Please take care of the lens, being cautious of the handling.

1. Turn the projector off, and unplug the power cord. Allow the projector to cool sufficiently.
2. After making sure that the projector is cool adequately, lightly wipe the lens with a commercially available lens-cleaning wipe. Do not touch the lens directly with your hand.

Caring for the cabinet and remote control

Incorrect care could have adverse influence such as discoloration, peeling paint, etc.

1. Turn the projector off, and unplug the power cord. Allow the projector to cool sufficiently.
2. Wipe lightly with gauze or a soft cloth.

If soiling is severe, dip soft cloth in water or a neutral cleaner dilute in water, and wipe lightly after wringing well. Then, wipe lightly with a soft, dry cloth.

Troubleshooting

Related messages

When the unit's power is on, messages such as those shown below may be displayed. When any such message is displayed on the screen, please respond as described below. If the same message is displayed after the treatment, or if a message other than the following appears, please contact your dealer or service company.

Although these messages will be automatically disappeared around several minutes, it will be reappeared every time the power is turned on.

Message	Description
NO INPUT IS DETECTED ON ***	There is no input signal. Please confirm the signal input connection, and the status of the signal source.
SYNC IS OUT OF RANGE ON *** <input type="text" value="fH"/> *****kHz <input type="text" value="fV"/> *****Hz	The horizontal or vertical wavelength of the inputted signal is outside of the response parameters of this unit. Please confirm the specs for this unit or the signal source specs.
CHECK THE AIR FLOW	The internal portion temperature is rising. Please turn the power OFF, and allow the unit to cool down at least 20 minutes. After having confirmed the following items, please turn the power ON again. <ul style="list-style-type: none"> ○ Is there blockage of the air passage aperture? ○ Is the air filter dirty? ○ Does the peripheral temperature exceed 35°C?

Message	Description
CLEAN THE AIR FILTER POWER OFF FIRST, AFTER CLEANING THE AIR FILTER, RESET THE FILTER TIMER	A note of precaution when cleaning the air filter. Please immediately turn the power OFF, and clean or change the air filter by referring to the "Air Filter" section of this manual. After you have cleaned or changed the air filter, please be sure to reset the filter timer. If the same message is displayed after the treatment, please clean the transparent area of filter cover and the dust-detecting window, according to the following.
To maximize performance, lamp replacement is recom- mended	When the projector lamp reaches 2000hours, this message is displayed.

Regarding the indicator lamps

Lighting and flashing of the POWER indicator, the LAMP indicator, and the TEMP indicator have the meanings as described in the table below. Please respond in accordance with the instructions within the table. If the same indication is displayed after the treatment, or if an indication other than the following is displayed, please contact your dealer or service company.

POWER indicator	LAMP indicator	TEMP indicator	Description
Lighting In Orange	Turned off	Turned off	The projector is in a standby state. Please refer to the section "Power On/Off".
Blinking In Green	Turned off	Turned off	The projector is warming up. Please wait.
Lighting In Green	Turned off	Turned off	The projector is in an on state. Ordinary operations may be performed.
Blinking In Orange	Turned off	Turned off	The projector is cooling down. Please wait.
Blinking In Red	(discretionary)	(discretionary)	The projector is cooling down. A certain error has been detected. Please wait until the POWER indicator finishes blink, and then perform the proper response measure using the item descriptions below as reference.
Blinking In Red or Lighting In Red	Lighting In Red	Turned off	The lamp does not light, and there is a possibility that interior portion has become heated. Please turn the power off, and allow the unit to cool down at least 20 minutes. After the projector has sufficiently cooled down, please make confirmation of the following items, and then turn the power on again. <ul style="list-style-type: none"> • Is there blockage of the air passage aperture? • Is the air filter dirty? • Does the peripheral temperature exceed 35°C? If the same indication is displayed after the treatment, please change the lamp by referring to the section "Lamp".
Blinking In Red or Lighting In Red	Turned off	Blinking In Red	The cooling fan is not operating. Please turn the power off, and allow the unit to cool down at least 20 minutes. After the projector has sufficiently cooled down, please make confirmation that no foreign matter has become caught in the fan, etc. and then turn the power on again. If the same indication is displayed after the treatment, please contact your dealer or service company.

POWER indicator	LAMP indicator	TEMP indicator	Description
Blinking In Red or Lighting In Red	Turned off	Lighting In Red	<p>There is a possibility that the interior portion has become heated.</p> <p>Please turn the power off, and allow the unit to cool down at least 20 minutes. After the projector has sufficiently cooled down, please make confirmation of the following items, and then turn the power on again.</p> <ul style="list-style-type: none"> • Is there blockage of the air passage aperture? • Is the air filter dirty? • Does the peripheral temperature exceed 35°C? <p>If the same indication is displayed after the treatment, please change the lamp by referring to the section "Lamp".</p>
Lighting In Green	Alternative blinking in Red		<p>There is a possibility that the interior portion has become overcooled.</p> <p>Please use the unit within the usage temperature parameters (5°C to 35°C). After the treatment, reset the power to ON.</p>
Lighting In Green	Simultaneous blinking in Red		<p>It is time to clean the air filter, or there is no air filter.</p> <p>Please immediately turn the power OFF, and clean or change the air filter by referring to the section "Air Filter". After cleaning or changed the lamp, please be sure to reset the filter timer. After the treatment, reset the power to ON.</p>

NOTE • When the interior portion has become overheated, for safety purposes, the power source is automatically turned off, and the indicator lamps may also be turned off. In such a case, press the "O" (OFF) side of the power switch, and wait at least 45 minutes. After the projector has sufficiently cooled down, please make confirmation of the attachment state of the lamp and lamp cover, and then turn the power on again.

Phenomena that may easily be mistaken for machine defects

WARNING

► Never use the projector if abnormal operations such as smoke, strange odor, excessive sound, damaged casing or elements or cables, penetration of liquids or foreign matter, etc. should occur. In such cases, immediately turn off the power switch and then disconnect the power plug from the power outlet. After making sure that the smoke or odor has stopped, contact your dealer or service company.

1. Before requesting repair, please check in accordance with the following chart. This operation sometimes resolves your problem.

If the situation cannot be corrected,

2. The projector's microprocessor may need to be reset. Please push the Restart switch by using a cocktail stick or similar and the projector will restart.
3. Some setting may be wrong. Please use the FACTORY RESET function of SERVICE menu in the OPTION menu to reset all settings to factory default.

Then, if the problem is not removed after maintenance, please contact your dealer or service company.

Phenomenon	Cases not involving a machine defect	Reference page
Power does not come on.	The electrical power cord is not plugged in. Correctly connect the power cord.	Connectiong power supply
	The power switch is not set to the on position. Set the power switch to [] (On).	Power on/off
	The main power source has been interrupted during operation such as by a power outage (blackout), etc. Please turn the power off, and allow the unit to cool down at least 20 minutes. After the projector has sufficiently cooled down, please turn the power on again.	Power on/off
	Either there is no lamp and/or lamp cover, or either of these has not been properly fixed. Please turn the power off, and allow the unit to cool down at least 45 minutes. After the projector has sufficiently cooled down, please make confirmation of the attachment state of the lamp and lamp cover, and then turn the power on again.	Lamp

Phenomenon	Cases not involving a machine defect	Reference page
No pictures are displayed.	The lens cover is closed. Remove the lens cover.	Part name Power on/off
	The signal cables are not correctly connected. Correctly connect the connection cables.	Connecting your devices
	The brightness is adjusted to an extremely low level. Adjust the BRIGHT to a higher level using the menu function or the remote control.	EASY MENU PICTURE menu
Colors have a faded-out appearance, or	Color settings are not correctly adjusted. Perform picture adjustments by changing the COLOR TINT, COLOR TEMP and/or COLOR SPACE settings, using the menu functions.	EASY MENU PICTURE menu INPUT menu
Color tone is poor.	COLOR SPACE setting is not suitable. Change the COLOR SPACE setting to AUTO, RGB, SMPTE240, REC709 or REC601.	INPUT menu
Pictures appear dark.	The brightness and/or contrast are adjusted to an extremely low level. Adjust the BRIGHT and/or CONTRAST settings to a higher level using the menu function.	EASY MENU PICTURE menu
	The WHISPER function is working. Select the NORMAL to the item WHISPER in the SETUP menu.	EASY MENU SETUP menu
	The lamp is approaching the end of its product lifetime. Replace the lamp.	Lamp
Pictures appear blurry.	Either the focus and/or horizontal phase settings are not properly. Adjust the focus using the focus ring, and/or H PHASE using the menu function.	Adjusting the zoom and focus IMAGE menu
	The lens is dirty or misty. Clean the lens by referring to the section "Other care".	Other care

NOTE • Although bright spots or dark spots may appear on the screen, this is a unique characteristic of liquid crystal displays, and such do not constitute or imply a machine defect.

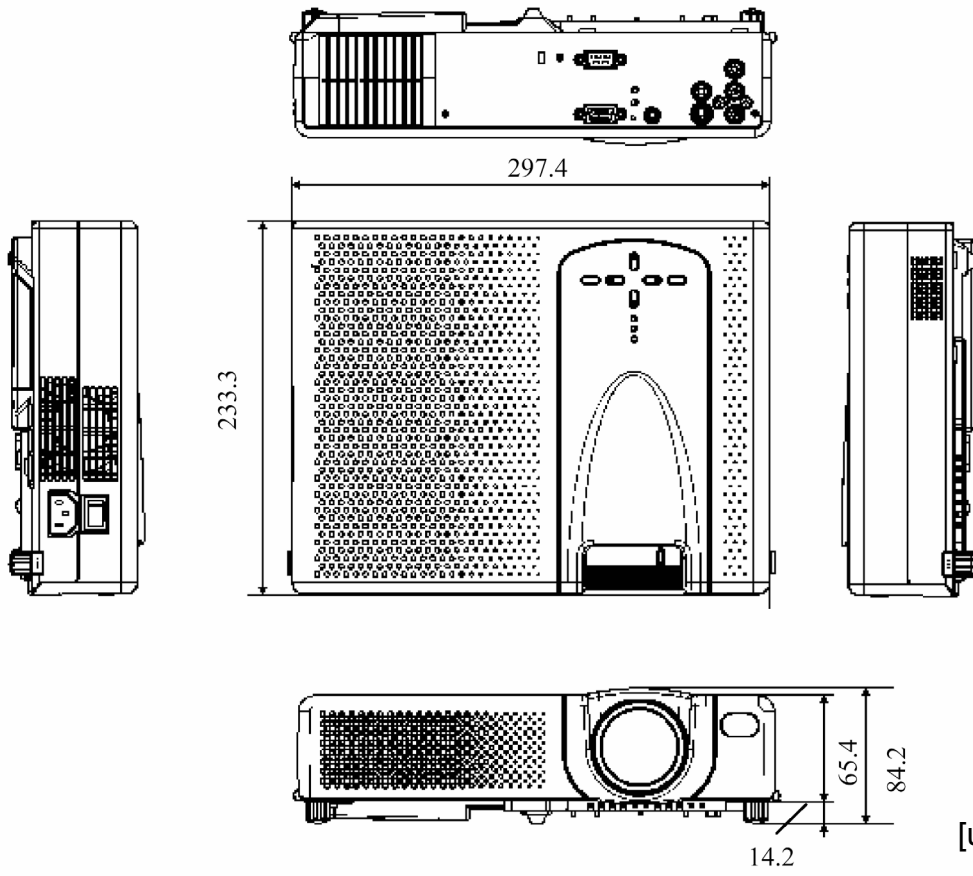

Customer Support

For technical support or product service, see the table below or contact your reseller.

NOTE: You will need the product serial number.

Country/ Region	Web site	T = Telephone F = FAX	Email
United States	www.viewsonic.com/sup- port	T: (800) 688-6688 F: (909) 468-1202	service.us@ viewsonic.com
Canada	www.viewsonic.com/sup- port	T: (800) 688-6688 F: (909) 468-1202	service.ca@ viewsonic.com
United Kingdom	www.viewsoniceurope.com	T: 0800 833 648 F: (01293) 643910	service.eu@ viewsoniceurope.com
Europe, Middle East, Baltic coun- tries, and North Africa	www.viewsoniceurope.com	Contact your reseller	service.eu@ viewsoniceurope.com
Australia and New Zealand	www.viewsonic.com.au	T: +61 2 9906 6277 F: +61 2 9906 6377	service@au. viewsonic.com
Singapore/ Malaysia/Thailand	www.viewsonic.com.sg	T: 65 273 4018 F: 65 273 1566	service@sg. viewsonic.com
South Africa/ Other countries	www.viewsonic.com	T: 886 2 2246 3456 F: 886 2 8242 3668	service@sd. viewsonic.com
Hong Kong	www.hk.viewsonic.com	T: 886 2 2246 3456 F: 886 2 8242 3668	service@hk. viewsonic.com

LIMITED WARRANTY

ViewSonic Projector

What the warranty covers:

ViewSonic® warrants its products to be free from defects in material and workmanship during the warranty period. If a product proves to be defective in material or workmanship during the warranty period, **ViewSonic** will at its sole option repair or replace the product with a like product. Replacement product or parts may include remanufactured or refurbished parts or components.

How long the warranty is effective:

ViewSonic projectors are warranted for two (2) years for all parts excluding the lamp, three (3) years for all labor, and one (1) year for the lamp from the date of the first consumer purchase.

Lamp warranty subject to terms and conditions, verification and approval. Applies to manufacturer's installed lamp only.

All accessory lamps purchased separately are warranted for 90 days.

Who the warranty protects:

This warranty is valid only for the first consumer purchaser.

What the warranty does not cover:

1. Any product on which the serial number has been defaced, modified or removed.
2. Damage, deterioration or malfunction resulting from:
 - a. Accident, misuse, neglect, fire, water, lightning, or other acts of nature, unauthorized product modification, or failure to follow instructions supplied with the product.
 - b. Repair or attempted repair by anyone not authorized by **ViewSonic**.
 - c. Any damage of the product due to shipment.
 - d. Removal or installation of the product.
 - e. Causes external to the product, such as electric power fluctuations or failure.
 - f. Use of supplies or parts not meeting **ViewSonic**'s specifications.
 - g. Normal wear and tear.
 - h. Any other cause which does not relate to a product defect.
3. Removal, installation, and set-up service charges.

How to get service:

1. For information about receiving service under warranty, contact **ViewSonic Customer Support**. You will need to provide your product's serial number.
2. To obtain warranted service, you will be required to provide (a) the original dated sales slip, (b) your name, (c) your address, (d) a description of the problem, and (e) the serial number of the product.
3. Take or ship the product freight prepaid in the original container to an authorized **ViewSonic** service center or **ViewSonic**.
4. For additional information or the name of the nearest **ViewSonic** service center, contact **ViewSonic**.

Limitation of implied warranties:

THERE ARE NO WARRANTIES, EXPRESS OR IMPLIED, WHICH EXTEND BEYOND THE DESCRIPTION CONTAINED HEREIN INCLUDING THE IMPLIED WARRANTY OF MERCHANTABILITY AND FITNESS FOR A PARTICULAR PURPOSE.

Exclusion of damages:

VIEWSONIC'S LIABILITY IS LIMITED TO THE COST OF REPAIR OR REPLACEMENT OF THE PRODUCT.

VIEWSONIC SHALL NOT BE LIABLE FOR:

1. DAMAGE TO OTHER PROPERTY CAUSED BY ANY DEFECTS IN THE PRODUCT, DAMAGES BASED UPON INCONVENIENCE, LOSS OF USE OF THE PRODUCT, LOSS OF TIME, LOSS OF PROFITS, LOSS OF BUSINESS OPPORTUNITY, LOSS OF GOODWILL, INTERFERENCE WITH BUSINESS RELATIONSHIPS, OR OTHER COMMERCIAL LOSS, EVEN IF ADVISED OF THE POSSIBILITY OF SUCH DAMAGES.
2. ANY OTHER DAMAGES, WHETHER INCIDENTAL, CONSEQUENTIAL OR OTHERWISE.
3. ANY CLAIM AGAINST THE CUSTOMER BY ANY OTHER PARTY.

Effect of state law:

This warranty gives you specific legal rights, and you may also have other rights which vary from state to state. Some states do not allow limitations on implied warranties and/or do not allow the exclusion of incidental or consequential damages, so the above limitations and exclusions may not apply to you.

Sales outside the U.S.A. and Canada:

For warranty information and service on **ViewSonic** products sold outside of the U.S.A. and Canada, contact **ViewSonic** or your local **ViewSonic** dealer.

Appendix

Power Cord Safety Guidelines

Caution: Use a power cable that is properly grounded. Always use an AC power cord that meets your country's safety standard.

USA.....UL
Canada.....CSA
Germany.....VDE

Switzerland.....SEV
Britain.....BASE/BS

AC PLUG CORD PRECAUTIONS FOR THE UNITED KINGDOM

FOR YOUR SAFETY PLEASE READ THE FOLLOWING TEXT CAREFULLY.

IF THE FITTED MOULDED PLUG IS UNSUITABLE FOR THE SOCKET OUTLET THEN THE PLUG SHOULD BE CUT OFF AND DISPOSED OF SAFELY.

THERE IS A DANGER OF SEVERE ELECTRICAL SHOCK IF THE CUT OFF PLUG IS INSERTED INTO AN APPROPRIATE SOCKET.

If a new plug is to be fitted, please observe the wiring code as shown below.

If in any doubt, please consult a qualified electrician.

WARNING: THIS APPLIANCE MUST BE EARTHED.

IMPORTANT: The wires in this mains lead are coloured in accordance with the following code:

Green-and-Yellow: Earth
Blue: Neutral
Brown: Live

If the coloured wires of the mains lead of this appliance do not correspond with the coloured markings identifying the terminals in your plug, proceed as follows:

The wire which is coloured GREEN-AND-YELLOW must be connected to the terminal in the plug which is marked by the letter E or by the Earth symbol or coloured GREEN or GREEN-AND-YELLOW.

The wire which is coloured BLUE must be connected to the terminal in the plug which is marked with the letter N or coloured BLACK. The wire which is coloured BROWN must be connected to the terminal in the plug which is marked with the letter L or coloured RED.

IMPORTANT NOTICE CONCERNING POWER CORD SELECTION

The power cord set for this unit has been enclosed and has been selected according to the country of destination and must be used to prevent electric shock. Use the following guidelines if it is necessary to replace the original cord set, or if the cord set is not enclosed.

The female receptacle of the cord set must meet CEE-22 requirements and may look like (Figure A1 below):

Figure 1 

For the United States and Canada

In the United States and Canada the male plug is a NEMA5-15 style (Figure A2), UL Listed, and CSA Labeled. For units which are mounted on a desk or table, type SVT cord sets may be used. The cord set must be selected according to the current rating for your unit. Please consult the table below for the selection criteria for power cords used in the United States and Canada.

Figure 2 

For customers in Canada:

Notice: This Class B digital apparatus complies with Canadian ICES-003.

Cord Type	Size of Conductors in Cord	Maximum Current Rating of Unit
SJT	18 AWG	10 Amps
	16 AWG	12 Amps
	14 AWG	12 Amps
SVT	18 AWG	10 Amps
	17 AWG	12 Amps

For European Countries

In Europe you must use a cord set which is appropriate for the receptacles in your country. The cord set is HAR-Certified, and a special mark that will appear on the outer sheath, or on the insulation of one of the inner conductors.

If you have any questions concerning which proper power cord to use, please consult with the dealer from whom you have purchased the product.

Compliance Information for U.S.A.

This equipment has been tested and found to comply with the limits for a Class B digital device, pursuant to part 15 of the FCC Rules. These limits are designed to provide reasonable protection against harmful interference in a residential installation. This equipment generates, uses, and can radiate radio frequency energy, and if not installed and used in accordance with the instructions, may cause harmful interference to radio communications. However, there is no guarantee that interference will not occur in a particular installation. If this equipment does cause harmful interference to radio or television reception, which can be determined by turning the equipment off and on, the user is encouraged to try to correct the interference by one or more of the following measures:

- Reorient or relocate the receiving antenna.
- Increase the separation between the equipment and receiver.
- Connect the equipment into an outlet on a circuit different from that to which the receiver is connected.
- Consult the dealer or an experienced radio/TV technician for help.

FCC Warning

To assure continued FCC compliance, the user must use grounded power supply cord and the provided shielded video interface cable with bonded ferrite cores. If a BNC cable is going to be used, use only a shielded BNC(5) cable. Also, any unauthorized changes or modifications not expressly approved by the party responsible for compliance could void the user's authority to operate this device.

Instructions to Users

This equipment complies with the requirements of FCC (Federal Communication Commission) equipment provided that the following condition is met. Use the cables which are included with the projector or specified.

Compliance Information for Canada

Notice: This class B digital apparatus complies with Canada ICES-003.

AVIS: Cet appareil numérique de la Classe B conforme a la norme NMB-003 du Canada.

Compliance Information for European Countries

CE Conformity



The device complies with the requirements of the EEC directive 89/336/EEC as amended by 92/31/EEC and 93/68/EEC Art.5 with regard to "Electromagnetic compatibility," and 73/23/EEC as amended by 93/68/EEC Art.13 with regard to "Safety."

User Information for all Countries

NOTICE: Use the cables which are included with the projector or specified.

ViewSonic Corporation